

BrassMaster

Time-clock water softener
Installation / Operation manual



Manufactured by:

Water Control Corporation
7150 143rd Ave NW
Ramsey, MN 55303
Tel: 763-427-9635
Fax: 763-427-5665

Installation procedure

1. **Identify installation location for water softener.** Piping should be such that all household water, with the exception of outside hydrants, flows through softener. A hard water line may be run to a kitchen tap if so desired. This system and installation must comply with state and local laws and regulations.
2. **Connect water piping.** This unit has been supplied with a manually operated bypass device which enables the softener to be isolated from the water service lines for maintenance and service, and also maintain the continuity of the water supply when the softener is disconnected. *Important: Make all sweat-solder connections within 6 inches of softener before applying threaded fittings to supplied bypass valve. Overheating may cause damage to valve.* Turn supplied bypass valve to “Bypass” position and make connections to household water lines. Leave unit in “Bypass” position until startup procedure.
3. **Connect drain line.** Remove barbed drain line fitting from parts bag. Apply Teflon tape to threads, and turn into the female threaded opening on the back side of the control valve. Connect 5/8” drain line (supplied in parts bag) to barbed end of drain line fitting, and run to a nearby drain. Be sure not to submerge drain line end into drain, as an 1 1/2” minimum air gap must be maintained to prevent potential backflow hazard. Firmly secure at drain, while maintaining a minimum 1 1/2” air gap (See detailed drawing on back side of piping diagram).
4. **Connect brine line (two-tank models only).** Connect 3/8” brine line (supplied in parts bag) to fitting on brine tank, and on the control valve. Tighten both fittings with an adjustable wrench.
5. **Install brine tank overflow line.** Install overflow fitting (supplied in parts bag) into hole in side of brine tank. An owner-supplied overflow line should then be attached and run to a nearby drain. *Failure to run overflow line could cause flooding and water damage should the brine tank overflow.*
6. **Connect to electrical power source.** Connect power cord to a dedicated 120v, 15 amp, ground fault interrupt (GFI) outlet.

Proceed to start-up procedure

Note: This system is not intended to be used for treating water that is microbiologically unsafe or of unknown quality without disinfection before or after the system.

Start-up procedure

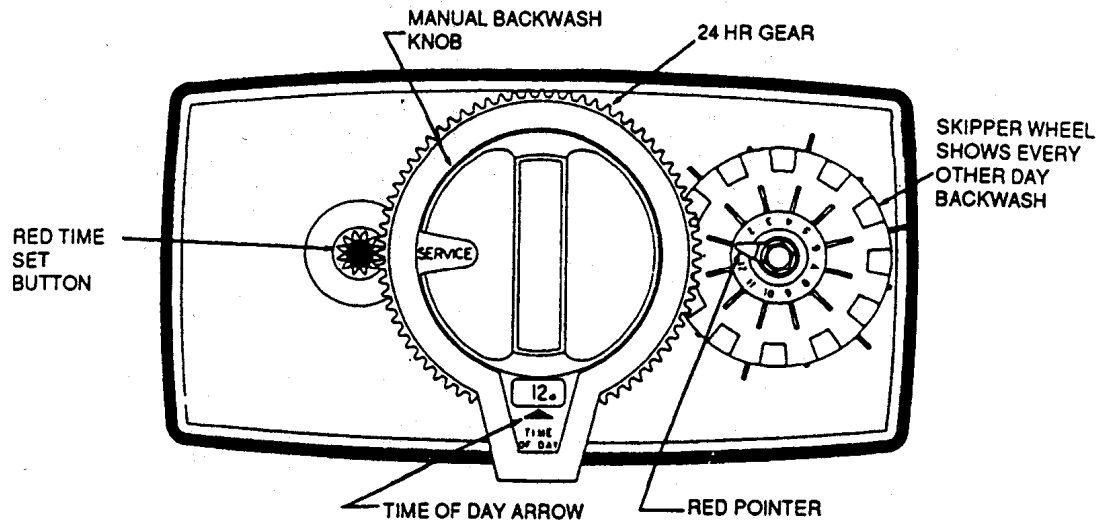

1. **Filling the mineral tank with water:** Turn the manual regeneration knob until “backwash” appears in the program window. Slowly turn bypass valve to the service position, allowing for water to fill the tank. When tank is full and all air has been bled from the system, water will flow to the drain line. Allow this water to flow for 3-4 minutes.
2. **Filling the brine tank with water:** Turn the manual regeneration knob until “brine fill” first appears in the program window. Water will begin to flow to the brine tank. Allow control to complete this cycle and return manual regeneration knob to the service position. This procedure will place the appropriate initial water fill in the brine tank.
3. **Setting the current time of day:** Depress red time set button on left side of control. While holding button, turn outer dial (24 hour gear) until the current time of day appears in the time of day window. This step should be repeated periodically to insure adjustment for power outages.
4. **Setting number of desired regeneration days:** Slide the pins on the skipper wheel outward for each day of regeneration desired during a 12 day period. See dealer for correct settings based on your water analysis and household size.

Warranty / Maintenance information



All BrassMaster water softeners feature the Assured Performance Modular (APM) design. If you experience a failure of any valve component, the brass module can be easily removed and replaced with a factory remanufactured replacement module.

To remove module, index the bypass valve to its “Bypass” position. Cycle control knob 360 degrees through complete cycle to relieve water pressure. Remove the stainless-steel retainer pins at the base of the module, loosen the clips at the bypass valve, and disconnect the drain line and brine line. The module will now completely separate from the tank. Please contact your dealer or the factory for module support.

Limited Warranty

Please see enclosed *Official Warranty* for complete warranty details.

Manufactured by:

Water Control Corporation
7150 143rd Ave NW
Ramsey, MN 55303
Tel: 763-427-9635
Fax: 763-427-5665