

# LENS™ Water Quality Monitoring System

Locate, evaluate, notify, solve.



Installation in water main, pipe, or recirculation loop



Installation in storage tank

## Real time monitoring of:

- Free chlorine\* (disinfectant)
- ORP (overall water health)
- Conductivity (dissolved contaminants)
- Temperature (biological growth potential)
- pH (potential corrosion/fouling)

## Plus:

- Data logging (6 mth)
- Alarms/BAS notifications\*\*

\*monochloramine sensor also available (must be specified)

\*\* 4 programmable dry contact relays plus BACnet and Modbus (TCP/IP)

## Additional capabilities

Up to four extra analog sensor inputs for monitoring of:

- Flow
- Pressure
- Turbidity
- Remote temperature
- Hardness
- Other contaminants

Control of external water safety/treatment equipment:

- Solenoid valves
- Filtration
- Disinfectant systems (chlorine injection, etc.)

# LENS™ Technical Details

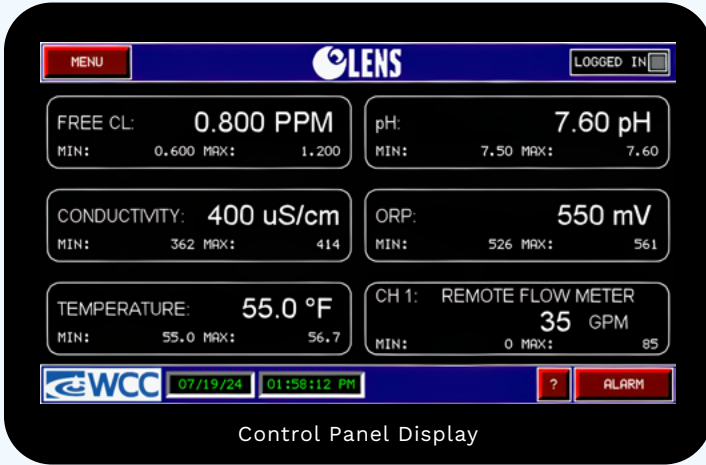

Control Panel Display

- Data logging (6 months, downloadable)
- Programmable alarms
- Programmable control relays
- Daily min/max and current values shown

Max operating temp:  
131°F (55°C)  
Max operating pressure:  
145psi (10bar)



Sensor

- Self cleaning, non-fouling
- 12 month service interval
- Wet tap sensor (pipe installations) can be removed/serviced without shutting down/draining system

Immersion Sensor  
(Tank Installations)

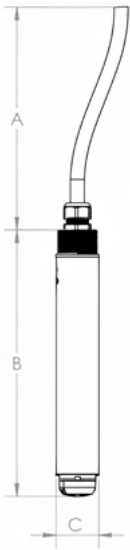

Wet Tap Sensor  
(Pipe Installation)

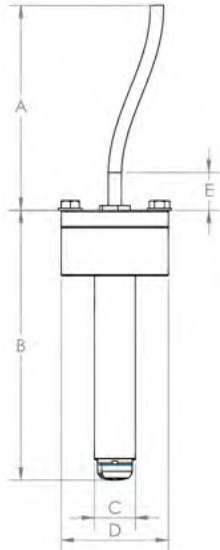

Sensor Dimensions

Sensor Dimensions		
A	Cable length	10', or to spec
B	Overall sensor length	11" (Immersion), 11.5" (Wet tap)
C	Diameter	1.72"
D	Wet tap removal tool diameter	4.5" (Wet tap only)
E	Required clearance for wet tap removal tool	13" (Wet tap only)

Wall-Mounted Control Panel

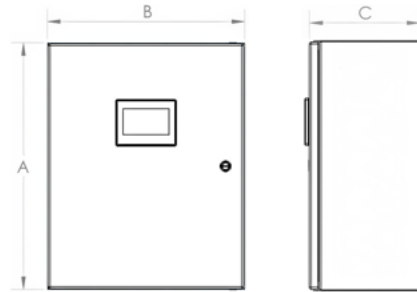

Panel Dimensions

Panel Dimensions		
A	Panel height	20"
B	Panel width	16"
C	Panel depth	8"

120v, 1ph, 3FLA (three prong plug provided for GFI outlet) (6' power cord)

## Contact WCC for:

DIV 22™ Specifications

Revit™ Families

Submittal/O&M Materials

To select a specific configuration, refer to LENS™ Model & Sizing Guide.



# LENS™ Water Quality Monitoring System



## Model and Sizing Guide

### Sensor and Control Packages

Model Number	Description	Disinfectant	Installation	Connection
1-210-15004	CHLORINE, WET TAP	Chlorine	In-pipe	2" NPTF
1-210-15005	CHLORINE, SUBMERSIBLE	Chlorine	In-tank	1" NPTM
1-210-15006	MONOCHLORAMINE, WET TAP	Monochloramine	In-pipe	2" NPTF
1-210-15007	MONOCHLORAMINE, SUBMERSIBLE	Monochloramine	In-tank	1" NPTM

### Wet Tap Sensor Installation Kits

Model Number	Description	Connection Type	Pipe Size	Material	Pipe Material
2-210-15000	LENS INSTALLATION KIT, 3 IN	Saddle	3	304 SS	Copper
2-210-15001	LENS INSTALLATION KIT, 4 IN	Saddle	4	304 SS	Copper
2-210-15002	LENS INSTALLATION KIT, 6 IN	Saddle	6	304 SS	Copper
2-210-15003	LENS INSTALLATION KIT, 3 IN	Saddle	3	304 SS	PVC, steel
2-210-15004	LENS INSTALLATION KIT, 4 IN	Saddle	4	304 SS	PVC, steel
2-210-15005	LENS INSTALLATION KIT, 6 IN	Saddle	6	304 SS	PVC, steel
2-210-15006	LENS INSTALLATION KIT, 3 IN	Flange	3	304 SS	Any 150# flange connection
2-210-15007	LENS INSTALLATION KIT, 4 IN	Flange	4	304 SS	Any 150# flange connection
2-210-15008	LENS INSTALLATION KIT, 6 IN	Flange	6	304 SS	Any 150# flange connection

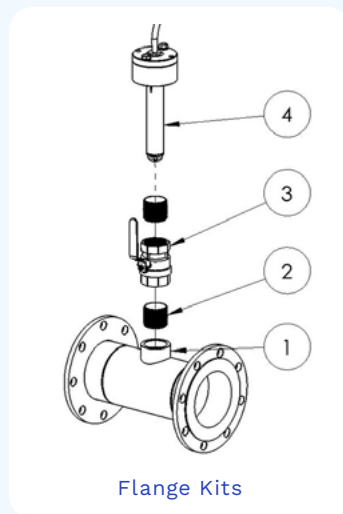
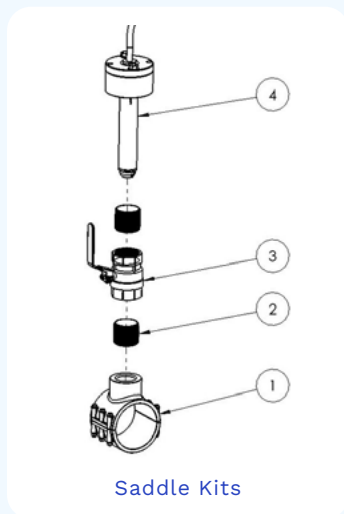

### Wet Tap Installations

Item Number	Description	Included?
1	Saddle or flanged spoolpiece	Yes, with Install Kit
2	Adaptor nipple	Yes, with Install Kit
3	Ball valve	Yes, with Install Kit
4	Water quality sensor	Yes, with Sensor/Control Package

